

Go to businessphones.vtech.com to register your product for enhanced warranty support and the latest VTech product news.

VNT814 4-Port Ethernet Router



vtech®

Abridged user's manual

Congratulations

on purchasing your new VTech product. Before using this router, please read **Important safety instructions**.

This abridged user's manual provides you with basic installation and use instructions. A limited set of features are described in abbreviated form.

Please refer to the online user's manual for a full set of installation and operation instructions at businessphones.vtech.com.

What's in the box

Your telephone package contains the following items. Save your sales receipt and original packaging in the event warranty service is necessary.

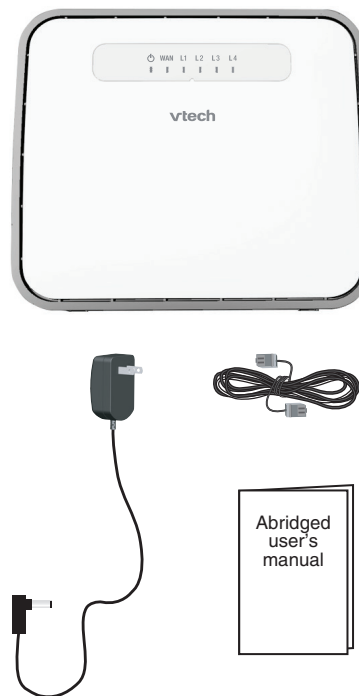

Overview

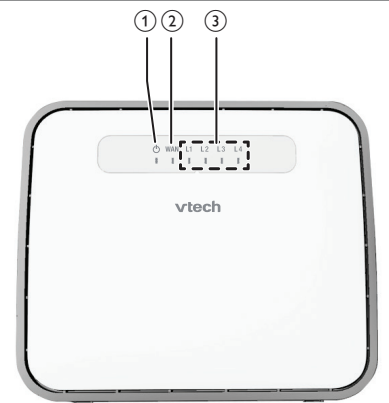

- 1 – **(On/Off) light**
 - On when the router is powered on.
- 2 – **WAN light**
 - On when the **WAN** port is connected.
 - Flashes when the router receives data from the **WAN** port.
- 3 – **L1 L2 L3 L4 lights**
 - On when the corresponding **LAN** port is connected.
 - Flashes when the corresponding **LAN** port receives data.

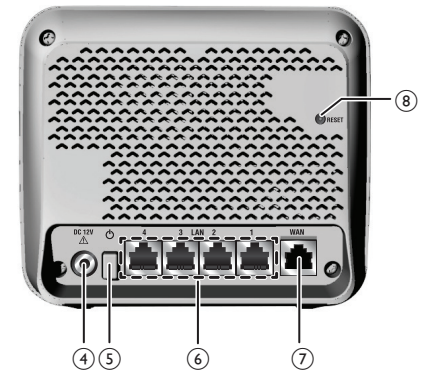

- 4 – **Power jack**
- 5 – **(On/Off) button**
 - Press to power on the router.
 - Press once again to power it off.
- 6 – **LAN ports**
 - Connect to Ethernet devices such as computers and SIP phones.
- 7 – **WAN port**
 - Connects to the wide area network.
- 8 – **RESET button**
 - Press and hold for five seconds to reset the router to default settings.

Plan and connect your system

This router has four LAN ports. Use them to connect your computers, SIP phones, or other Ethernet devices.

NOTES

- Use only the adapter provided.
- Make sure the electrical outlet is not controlled by a wall switch.
- The adapter is intended to be correctly oriented in a vertical or floor mount position. The prongs are not designed to hold the plug in place if it is plugged into a ceiling, under-the-table or cabinet outlet.

To power on, press **(On/Off) button** at the back of the router. The **(On/Off) light** will light up.

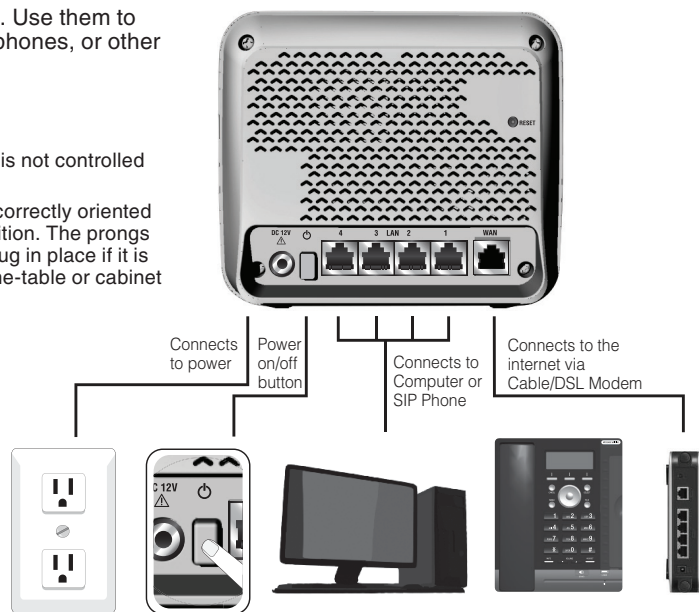

To connect more than four Ethernet devices, you can purchase additional VNT814 router(s), and then connect them to the parent router. See below graphic for more details.

NOTES

- Make sure you have connected all routers and devices before you power on any router or device.
- Follow this sequence to power on the system: (1) Parent router, (2) Child routers, (3) other Ethernet devices.
- Child routers enter Auto Bridge Mode. All Ethernet devices obtain IP addresses from the parent router directly.

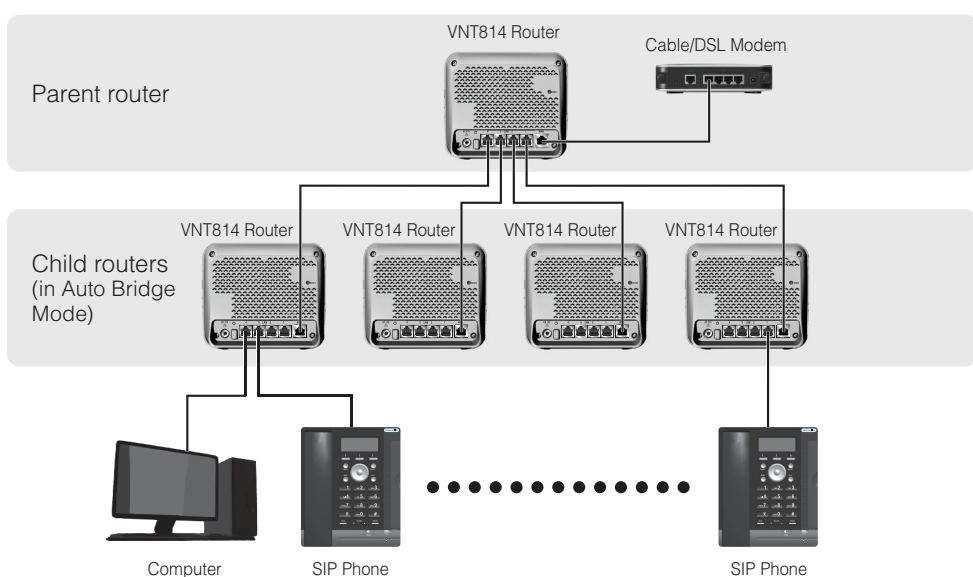

Configure your router

Browse the web management page

When you login to the web management page, you can browse the router settings and change them if necessary.

TIPS

- Before you browse the web management page, open **Internet Properties** of your computer and check the settings. Make sure you do not use a proxy server for LAN settings.
- Check the property of your Internet protocol. Make sure it can obtain an IP address automatically. Do not use a fixed IP address.

1. Connect your computer to the router.
2. Open a browser on your computer.
3. Type **192.168.1.1** in the address bar, and then press enter.
4. Input username and password to login to the router. The table below shows the default username and password.

	Username	Password
Administrative account	admin	admin12345
Normal user account	user	user1234

NOTE

- Both administrative account and normal user account can view the router settings. To change the settings, you must login as an administrative account.

Change username and password

NOTE

- For security purposes, we recommend you change the username and password periodically.

1. On the web management page, click **Maintenance** on the menu bar.
2. Click **Password** on the side menu.
3. Fill in respective text boxes to add, modify or delete an account.

General product care

Taking care of your router

Your router contains sophisticated electronic parts, so it must be treated with care.

Avoid rough treatment

Place the router down gently. Save the original packing materials to protect your router if you ever need to ship it.

Avoid water

Your router can be damaged if it gets wet. Do not use the router outdoors in the rain, or handle it with wet hands. Do not install the router near a sink, bathtub or shower.

Electrical storms

Electrical storms can sometimes cause power surges harmful to electronic equipment. For your own safety, take caution when using electrical appliances during storms.

Cleaning your router

Your router has a durable plastic casing that should retain its luster for many years. Clean it only with a dry non-abrasive cloth. Do not use dampened cloth or cleaning solvents of any kind.

Frequently asked questions

Below are the questions most frequently asked about the router. If you cannot find the answer to your question, visit our website at businessphones.vtech.com or call **1 (888) 370-2006** for customer service.

My router does not work.	<p>Make sure you install the router properly, and the electrical outlet is not controlled by a wall switch.</p> <p>Make sure the router is powered on and the (On/Off) light is on.</p>
My router cannot load data from the Internet.	<p>Make sure you connect the WAN port properly. DO NOT mix up the WAN port with LAN ports.</p> <p>Press and hold the RESET button for five seconds, and then wait for a few minutes for the router to restart. Observe the WAN light, it flashes when the router receives data.</p> <p>NOTE: The router resets to default settings. Use the default usernames and passwords to login to the web management page.</p> <p>Disconnect the Ethernet cable from the router and connect it to a different router. If there is no signal on that router either, the problem is in your wiring or local service. Contact your Internet service provider.</p>
	Your Ethernet cable might be defective. Try installing a new one.

Important safety instructions

When using your equipment, basic safety precautions should always be followed to reduce the risk of fire, electric shock and injury, including the following:

1. Read and understand all instructions.
2. Do not use this product near water such as near a bath tub, wash bowl, kitchen sink, laundry tub or a swimming pool, or in a wet basement or shower.
3. Do not place this product on an unstable table, shelf, stand or other unstable surfaces.
4. **CAUTION:** Use only the adapters included with this product. Incorrect adapter polarity or voltage can seriously damage the product.
Power adapter: Input 100-240V AC 200mA 50/60Hz; Output: 12V DC 500mA
5. The power adapters are intended to be correctly oriented in a vertical or floor mount position. The prongs are not designed to hold the plug in place if it is plugged into a ceiling, under-the-table or cabinet outlet.
6. For pluggable equipment, the socket-outlet shall be installed near the equipment and shall be easily accessible.
7. Unplug this product from the wall outlet before cleaning. Do not use liquid or aerosol cleaners. Use a damp cloth for cleaning.
8. Do not cut off the power adapters to replace them with other plugs, as this causes a hazardous situation.
9. Do not allow anything to rest on the power cords. Do not install this product where the cords may be walked on or crimped.
10. This product should be operated only from the type of power source indicated on the marking label. If you are not sure of the type of power supply in your home, consult your dealer or local power company.
11. Do not overload wall outlets or use an extension cord.
12. This product should not be placed in any area where proper ventilation is not provided. Slots and openings in the back or bottom of this product are provided for ventilation. To protect them from overheating, these openings must not be blocked by placing the product on a soft surface such as a bed, sofa or rug. This product should never be placed near or over a radiator or heat register.
13. Never push objects of any kind into this product through the slots because they may touch dangerous voltage points or create a short circuit. Never spill liquid of any kind on the product.
14. To reduce the risk of electric shock, do not disassemble this product, but take it to an authorized service facility. Opening or removing parts of the product other than specified access doors may expose you to dangerous voltages or other risks. Incorrect reassembling can cause electric shock when the product is subsequently used.
15. Periodically examine all components for damage.

SAVE THESE INSTRUCTIONS

What is not covered by this limited warranty?

This limited warranty does not cover:

1. Product that has been subjected to misuse, accident, shipping or other physical damage, improper installation, abnormal operation or handling, neglect, inundation, fire, water or other liquid intrusion;
2. Product that has been damaged due to repair, alteration or modification by anyone other than an authorized service representative of VTech;
3. Product to the extent that the problem experienced is caused by signal conditions, network reliability, or cable or antenna systems;
4. Product to the extent that the problem is caused by use with non-VTech accessories;
5. Product whose warranty/quality stickers, product serial number plates or electronic serial numbers have been removed, altered or rendered illegible;
6. Product purchased, used, serviced, or shipped for repair from outside the United States of America or Canada, or used for commercial or institutional purposes (including but not limited to Products used for rental purposes);
7. Product returned without a valid proof of purchase (see item 2 below); or
8. Charges for installation or set up, adjustment of customer controls, and installation or repair of systems outside the unit.

How do you get warranty service?

To obtain warranty service in the USA and Canada, please visit our website at businessphones.vtech.com or call 1 (888) 370-2006.

NOTE: Before calling for service, please review the user's manual - a check of the Product's controls and features may save you a service call.

Except as provided by applicable law, you assume the risk of loss or damage during transit and transportation and are responsible for delivery or handling charges incurred in the transport of the Product(s) to the service location. VTech will return repaired or replaced Product under this limited warranty. Transportation, delivery or handling charges are prepaid. VTech assumes no risk for damage or loss of the Product in transit. If the Product failure is not covered by this limited warranty, or proof of purchase does not meet the terms of this limited warranty, VTech will notify you and will request that you authorize the cost of repair prior to any further repair activity. You must pay for the cost of repair and return shipping costs for the repair of Products that are not covered by this limited warranty.

What must you return with the Product to get warranty service?

1. Return the entire original package and contents including the Product to the VTech service location along with a description of the malfunction or difficulty; and
2. Include a "valid proof of purchase" (sales receipt) identifying the Product purchased (Product model) and the date of purchase or receipt; and
3. Provide your name, complete and correct mailing address, and telephone number.

Electromagnetic fields (EMF)

This VTech product complies with all standards regarding electromagnetic fields (EMF). If handled properly and according to the instructions in this user's manual, the product is safe to be used based on scientific evidence available today.

FCC and IC regulations

FCC part 15

This equipment has been tested and found to comply with the requirements for a Class B digital device under Part 15 of the Federal Communications Commission (FCC) rules. These requirements are intended to provide reasonable protection against harmful interference in a residential installation. This equipment generates, uses and can radiate radio frequency energy and, if not installed and used in accordance with the instructions, may cause harmful interference to radio communications. However, there is no guarantee that interference will not occur in a particular installation. If this equipment does cause harmful interference to radio or television reception, which can be determined by turning the equipment off and on, the user is encouraged to try to correct the interference by one or more of the following measures:

- Reorient or relocate the receiving antenna.
- Increase the separation between the equipment and receiver.
- Connect the equipment into an outlet on a circuit different from that to which the receiver is connected.
- Consult the dealer or an experienced radio/TV technician for help.

WARNING: Changes or modifications to this equipment not expressly approved by the party responsible for compliance could void the user's authority to operate the equipment.

This device complies with Part 15 of the FCC rules. Operation is subject to the following two conditions: (1) this device may not cause harmful interference, and (2) this device must accept any interference received, including interference that may cause undesired operation.

This Class B digital apparatus complies with Canadian requirement:

CAN ICES-3 (B)/NMB-3(B).

For cETL compliance only

Mesures de sécurité importantes

Lorsque vous utilisez votre appareil, vous devriez toujours suivre certaines mesures de précaution de base afin de réduire les risques d'incendie, d'électrocution et de blessures corporelles, dont ceux qui suivent :

1. Lisez et comprenez bien toutes les instructions.
2. N'utilisez pas cet appareil près de l'eau ni de toute autre source d'humidité, par exemple, près

d'une baignoire, cuve à lessive, évier de cuisine, dans un sous-sol humide ni près d'une piscine, dans un sous-sol humide ou une douche.

3. Ne déposez pas ce téléphone sur un chariot, support ou table chancelants. L'appareil pourrait tomber et être sérieusement endommagé.
4. **MISE EN GARDE :** N'utilisez que les adaptateurs inclus avec ce produit. L'utilisation d'un adaptateur dont la polarité ou la tension serait inadéquate risque d'endommager sérieusement le produit et mettre votre sécurité en péril.
Adaptateur : Entrée 100-240V CA 200 mA 50/60 Hz; Sortie : 12 V CC 500 mA
5. Lorsqu'ils sont branchés dans une prise de courant, les adaptateurs secteur ont été conçus pour être orientés correctement, soit à la verticale ou au plancher. Les broches n'ont pas été conçues pour supporter le poids du bloc d'alimentation et le maintenir en place si celui-ci est branché dans une prise au plafond, sous une table ou dans un meuble.
6. Pour les PRODUITS À BRANCHER À UNE PRISE DE COURANT, la prise de courant doit être installée près du produit, afin d'assurer une accessibilité sécuritaire à la prise de courant.
7. Débranchez ce produit de la prise de courant avant de procéder au nettoyage. N'utilisez pas de nettoyeurs en aérosols. Utilisez un chiffon humide pour le nettoyer.
8. Ne coupez pas les cordons d'alimentation pour remplacer les fiches, car ceci peut présenter un danger potentiel.
9. Ne laissez aucun objet reposer ni appuyer sur le cordon d'alimentation. N'installez pas cet appareil dans un endroit où l'on risque d'écraser le cordon d'alimentation ou de le piétiner.
10. Ne faites fonctionner cet appareil qu'avec le type d'alimentation indiqué sur l'étiquette. Si vous ne connaissez pas le type d'alimentation que vous possédez à votre domicile, consultez votre marchand ou votre compagnie locale d'électricité.
11. Ne surchargez pas les prises de courant murales ni les rallonges électriques.
12. Les trous et ouvertures du boîtier, situés à l'arrière de l'appareil ou sous celui-ci, servent à aérer l'appareil. Pour l'empêcher de surchauffer, ne bloquez sous aucun prétexte ces ouvertures et n'empêchez pas l'aération adéquate de l'appareil en le plaçant sur un lit, divan, tapis ou toute autre surface similaire. De même, ne le positionnez pas à proximité ni au-dessus d'une source de chaleur ou d'un calorifère. De plus, ne placez pas l'appareil dans un endroit avant de vous assurer qu'il y ait une bonne circulation d'air.
13. N'enfoncez jamais d'objets à travers les ouvertures de cet appareil, car ils pourraient entrer en contact avec des points de tension dangereux ou causer des courts-circuits qui peuvent dégénérer en incendies ou en risques d'électrocution. Ne renversez jamais de liquide dans ce produit.
14. Afin de réduire les risques d'électrocution, ne démontez pas cet appareil, mais apportez-le

dans un centre de service autorisé. L'ouverture du boîtier ou le retrait de toutes pièces que contient cet appareil, à l'exception de l'accès autorisé à certaines portes ou ouvertures, risque de vous exposer à des points de tension dangereux ou d'autres dangers. Un remontage incorrect peut par la suite présenter des risques d'électrocution.

15. Examinez les composantes afin de vérifier si celles-ci ne sont pas endommagées.

CONSERVEZ CES INSTRUCTIONS

Champs électromagnétiques (EMF)

Ce produit de VTech est conforme à toutes les normes se rapportant aux champs électromagnétiques (EMF) standard. Si vous le manipulez correctement en suivant les instructions de ce guide, son utilisation sera sécuritaire pendant de nombreuses années, selon les meilleures évidences scientifiques dont nous disposons aujourd'hui.

Limited warranty

What does this limited warranty cover?

The manufacturer of this VTech Product warrants to the holder of a valid proof of purchase ("Consumer" or "you") that the Product and all accessories provided in the sales package ("Product") are free from defects in material and workmanship, pursuant to the following terms and conditions, when installed and used normally and in accordance with the Product operating instructions. This limited warranty extends only to the Consumer for Products purchased and used in the United States of America and Canada.

What will VTech do if the Product is not free from defects in materials and workmanship during the limited warranty period ("Materially Defective Product")?

During the limited warranty period, VTech's authorized service representative will repair or replace at VTech's option, without charge, a Materially Defective Product. If we repair the Product, we may use new or refurbished replacement parts. If we choose to replace the Product, we may replace it with a new or refurbished Product of the same or similar design. We will retain defective parts, modules, or equipment. Repair or replacement of the Product, at VTech's option, is your exclusive remedy. VTech will return the repaired or replacement Products to you in working condition. You should expect the repair or replacement to take approximately 30 days.

How long is the limited warranty period?

The limited warranty period for the Product extends for TWO (2) YEARS from the date of purchase. If VTech repairs or replaces a Materially Defective Product under the terms of this limited warranty, this limited warranty also applies to the repaired or replacement Product for a period of either (a) 90 days from the date the repaired or replacement Product is shipped to you or (b) the time remaining on the original one-year warranty; whichever is longer.

Other limitations

This warranty is the complete and exclusive agreement between you and VTech. It supersedes all other written or oral communications related to this Product. VTech provides no other warranties for this Product. The warranty exclusively describes all of VTech's responsibilities regarding the Product. There are no other express warranties. No one is authorized to make modifications to this limited warranty and you should not rely on any such modification.

State/Provincial Law Rights: This warranty gives you specific legal rights, and you may also have other rights, which vary from state to state or province to province.

Limitations: Implied warranties, including those of fitness for a particular purpose and merchantability (an unwritten warranty that the Product is fit for ordinary use) are limited to one year from the date of purchase. Some states/provinces do not allow limitations on how long an implied warranty lasts, so the above limitation may not apply to you. In no event shall VTech be liable for any indirect, special, incidental, consequential, or similar damages (including, but not limited to lost profits or revenue, inability to use the Product or other associated equipment, the cost of substitute equipment, and claims by third parties) resulting from the use of this Product. Some states/provinces do not allow the exclusion or limitation of incidental or consequential damages, so the above limitation or exclusion may not apply to you.

Please retain your original sales receipt as proof of purchase.

Technical specifications

Operating temperature	32°F - 104°F 0°C - 40°C
Power requirements	Input: 100-240V AC 50/60Hz Output: 12V DC 500mA
Ethernet Network Ports	10/100 Mbps RJ-45 Port



Specifications are subject to change without notice.
© 2016 VTech Communications, Inc.
All rights reserved. 02/16. VNT814_ACIB_V3.0
Document order number: 91-008805-030-100

